



Winnox Burners

Model WX0200

Version 1

Main Specifications

PARAMETER		SPECIFICATIONS	
Blower Type		Packaged blower	Remote blower
Maximum input, BTU/hr (kW)  Note: <i>Capacities given without air filter.</i> <i>Contact factory for chamber pressures outside the given range, or varying chamber pressure conditions.</i>	Chamber pressure "WC (mbar)	Nominal (60 Hz)	Pressure at air inlet 1 psig (70 mbar)
	-5.0 (-12.5)	2,275,000 (667)	2,610,000 (765)
	-3.0 (-7.5)	2,170,000 (634)	2,525,000 (740)
	0.0	2,000,000 (586)	2,400,000 (703)
	1.0 (2.5)	1,940,000 (568)	2,355,000 (690)
	2.0 (5.0)	1,880,000 (551)	2,310,000 (677)
Minimum input, BTU/hr (kW)		150,000 (39)	
Fuel inlet pressure at ratio regulator, "w.c. (mbar) ¹⁾	Maximum	40.0 (100)	40.0 (100)
	Minimum	23.0 (58)	30.0 (75)
Maximum chamber temperature, °F (°C) <i>Note: Tube and plug temperatures should be reduced 150°F when using propane or butane.</i>		Standard combustion tube: 1300 (704) High temp. combustion tube: 1550 (843) Refractory Plug: 1800 (982)	
Flame Length	Alloy Tube	Flame is inside tube at all inputs	
Excess Air, % at high fire		40%	
Piping		N.P.T. or B.S.P. burner piping available	
Flame detection		Flame Rod or U.V. Scanner	
Fuels		Natural gas ²⁾ <i>For any other mixed gas, contact Eclipse Combustion</i>	
Blower Motor Power, hp		3.0	
Weight, lbs (kg)	Alloy Tube	262 (119)	180 (82)
	Refractory Plug	235 (106)	153 (70)

- 1) For proper performance, this pressure must be kept constant across the burner operating range.
 2) See Design Guide for more information about typical fuel composition and properties.

- All information is based on laboratory testing. Different chamber size and conditions will affect data.
- Maximum inputs for packaged blower versions are given for the standard combustion air blower without an inlet air filter.
- All inputs are based on gross calorific values and standard conditions: one atmosphere, 70° F (21° C)
- Eclipse reserves the right to change the construction and/or configuration of our products at any time without being obliged to adjust earlier supplies accordingly.

Performance Graphs WX0200

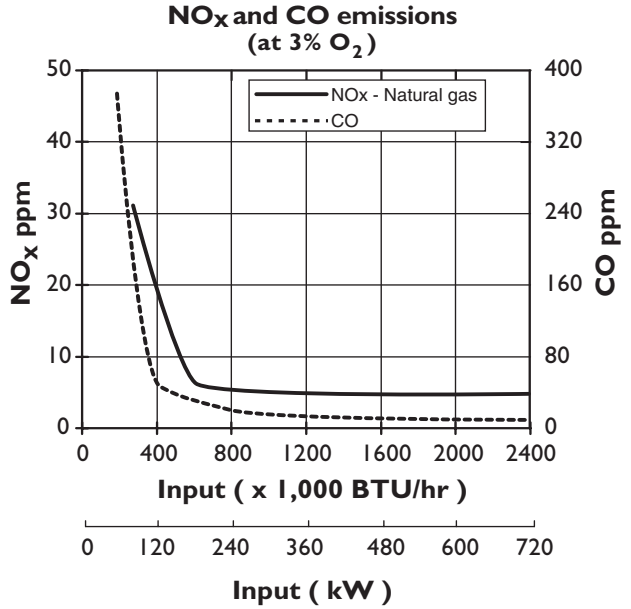
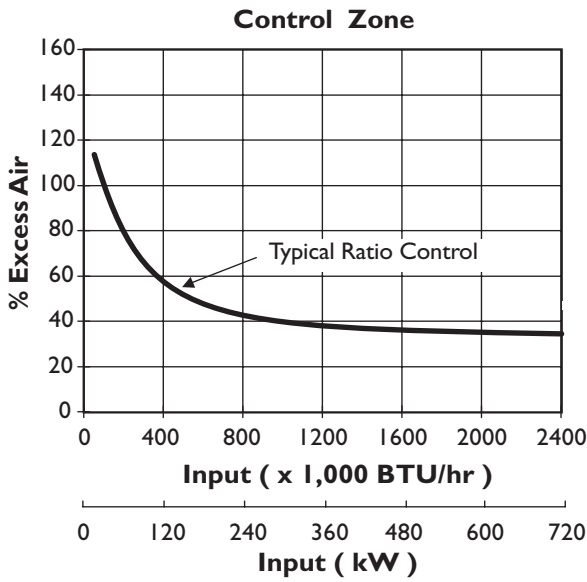

Input at low fire changes with ratio regulator adjustment.

Secondary by-pass fuel setting:

FUEL	ΔP "w.c. (mbar)*
Nat. Gas	4.0 (10.0)

* Measured between Tap "E" and the chamber @ low fire.

- NO_x and CO emission data is given for:
- Ambient combustion air (~70 °F, 20 °C)
 - Less than 1000 °F (540 °C) firing chamber
 - Minimal process air velocity
 - Low fire input adjusted to 350,000 BTU/hr (103kW)
 - Neutral chamber pressure

- Emissions are influenced by:
- Chamber conditions
 - Fuel type
 - Firing rate
 - Ratio regulator adjustments
 - Combustion air temperature

CO emission is largely influenced by chamber conditions. Contact your local Eclipse Combustion representative for an estimate of CO emission on your application.

Fuel / Input Measurement

System design must include fuel flow measurement upstream of the burner. Recommended is the Eclipse 6-5 FOM (Fuel Orifice Meter) assembly number 302086-5 for natural gas. See Bulletin 930 for details

Insure burner inlet pressures are met.

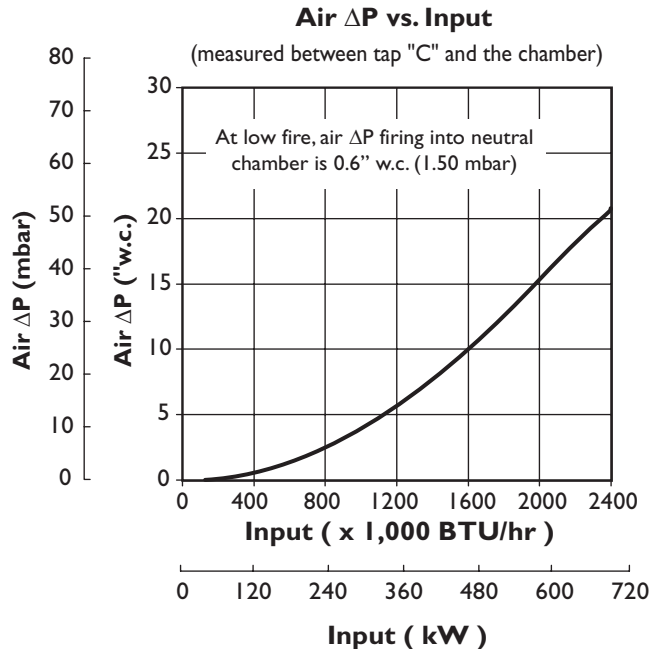

**Dimensions
WX0200**

Dimensions in mm (in)

Packager Blower

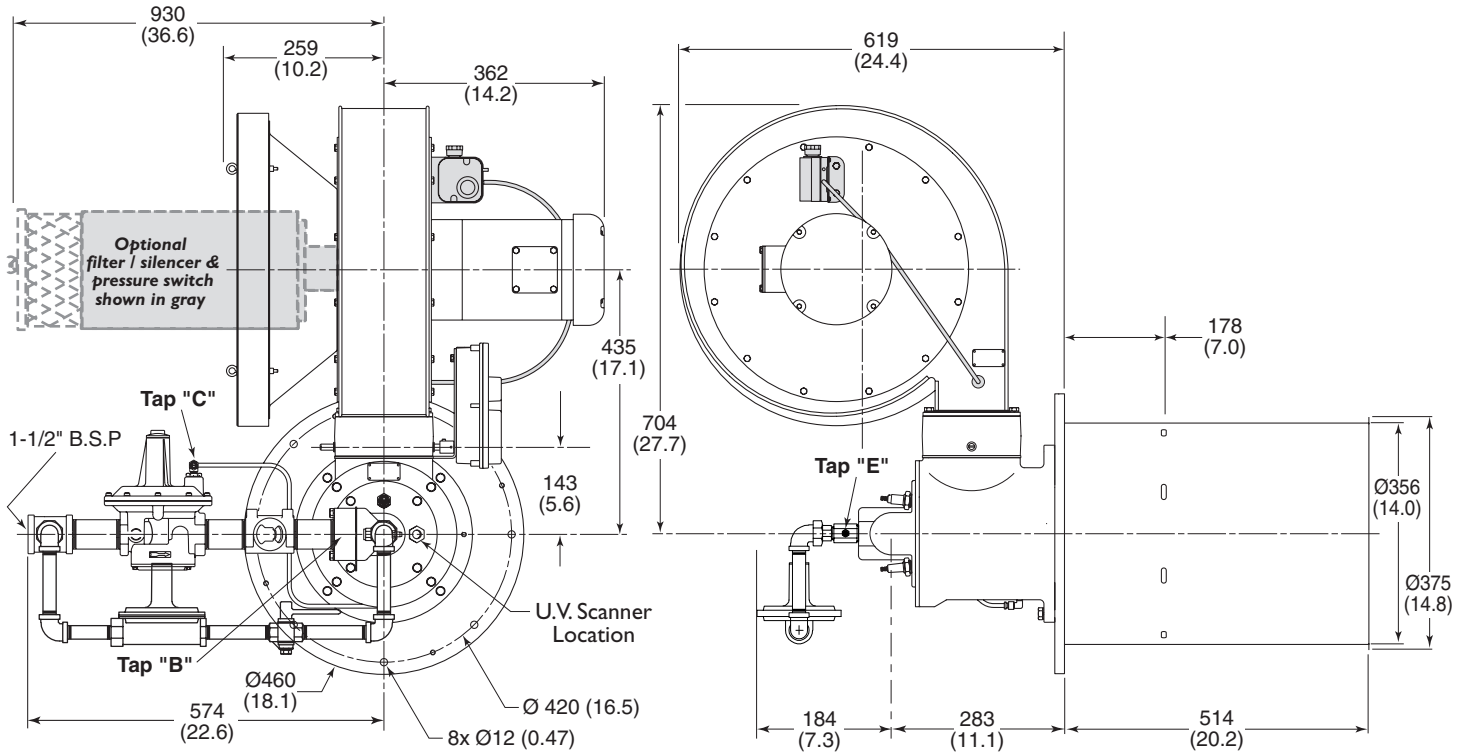

Refractory Plug

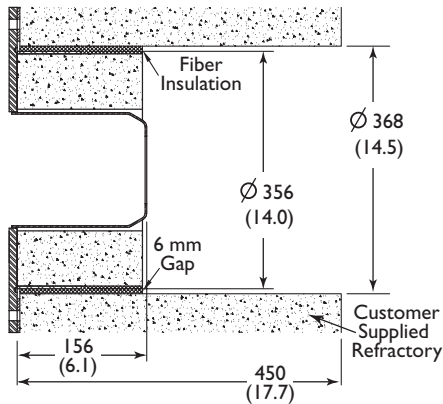

Configured for Pilot

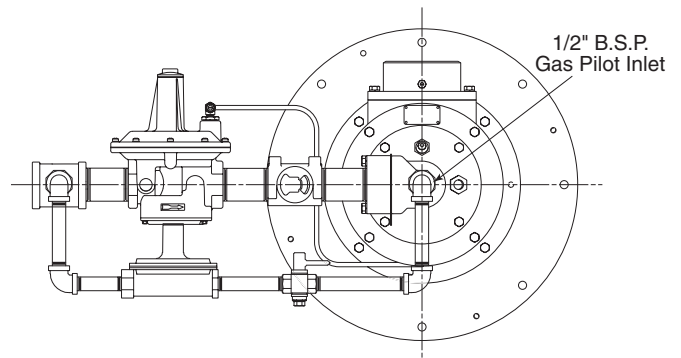

Remote Blower

Note: For Remote Blower applications, consult factory.

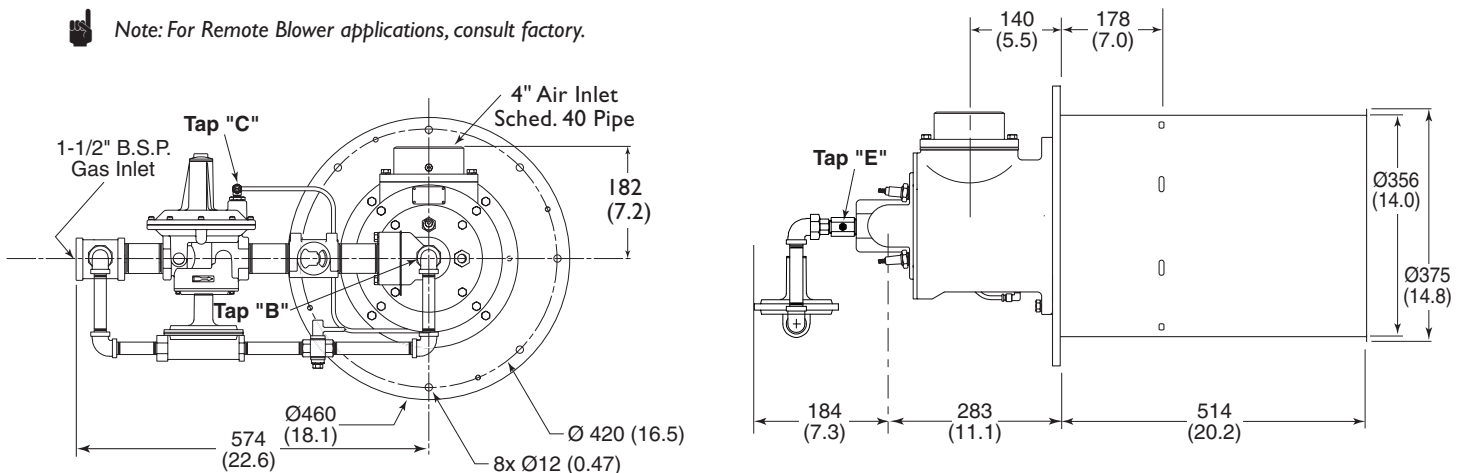



Offered By:

Power Equipment Company
2011 Williamsburg Road
Richmond, Virginia 23231
Phone (804) 236-3800
Fax (804) 236-3882

www.peconet.com